

SERIAL #:



**Before assembling please note:**  
Natural gas conversion kit is available  
at Canadian Tire #85-1621-4

# Entertainment Island 6000 SI Barbecue

SAFE USE, CARE AND ASSEMBLY MANUAL



## DANGER

### If You Smell Gas

1. Shut off gas to the appliance.
2. Extinguish any open flame.
3. Open lid.
4. If odor continues, keep away from the appliance and immediately call your gas supplier or your fire department.

## WARNING

1. Do not store or use gasoline or other flammable liquids or vapors in the vicinity of this or any other appliance.
2. An LP cylinder not connected for use shall not be stored in the vicinity of this or any other appliance.

## WARNING

Failure to follow all of the manufacturer's instructions could result in hazardous fires, explosions, property damage, or serious personal injury or even death.

## WARNING

Follow all leak check procedures carefully prior to operation of barbecue, even if barbecue was store assembled. Do not try to light this barbecue without reading the Lighting Instructions section of this manual.



HEAVY ARTICLE NEEDS 2 TO LIFT

5 YEAR LIMITED WARRANTY  
85-1620-6 PROPANE (G61501)

Read and save this manual for future reference.

If pre-assembled, leave this manual with  
unit for consumer's future reference.

Centro Customer Care Hotline  
**1-877-707-5463**

**THIS BARBECUE IS FOR  
OUTDOOR USE ONLY**

## TABLE OF CONTENTS

|  |       |
|--|-------|
| Warranty . . . . .   | ii    |
| Installation Information . . . . .   | 1     |
| Additional Warnings . . . . .  | 1     |
| Use of LP Gas Cylinder, . . . . .  | 1-2   |
| Transportation and<br>Storage of the LP Cylinder,<br>Filling the LP Cylinder     |       |
| Prior to Using the Grill . . . . .   | 3     |
| Safety Hose and Regulator . . . . .  | 4     |
| Safety Leak Testing . . . . .  | 5     |
| Lighting the Grill . . . . .   | 6-8   |
| Sear Zone . . . . .  | 9     |
| Operating Instruction  |       |
| Rotisserie Burner . . . . .  | 10    |
| Operating Instructions   |       |
| Tips On Using . . . . .  | 10    |
| Your Rotisserie  |       |
| Parts List, Parts Diagram, . . .   | 12-15 |
| and Hardware Pack for<br>Centro 6000SI Barbecue and<br>Multi-purpose Side Burner |       |
| Parts List, Parts Diagram, . . .   | 16-17 |
| and Hardware Pack<br>for Entertainment Island                                    |       |
| Assembly Instructions . . . . .  | 18    |



## WARRANTY

### 5 Year Limited Warranty

This Centro BBQ carries a five year limited warranty against defects in manufacturing workmanship. This Limited Warranty is nontransferable and becomes void if used for commercial or rental purposes. This warranty applies only when grill is used in Canada. The bill of sale or a copy will be required together with the serial number and model number when making any warranty claims from Trileaf Distribution. Trileaf Distribution reserves the right to have its representatives inspect any product or part prior to honouring any warranty claim. Trileaf Distribution shall not be liable for any transportation charges, shipping and handling charges, or labour cost. This warranty is for replacement of defective parts only. The Manufacturer will not be responsible for incidental or consequential damages or any labor cost. Inability to provide proof of purchase, or if warranty coverage has expired, any request for parts will be subject to parts, shipping and handling fees. This limited warranty does not cover damage due to chipping and scratching of porcelain or painted surfaces including Cooking grates, nor does it cover corrosion or discolouration due to misuse, lack of maintenance, grease fires, hostile environments, accidents, alterations, abuse or neglect, improper installation and failure to read and/or abide by any product warnings. This limited warranty does not cover any damage sustained during removal or storage of this BBQ. Part failure due to lack of cleaning and maintenance, or use of improper cleaning products such as Oven Cleaner will not be covered under this manufacturers warranty. This limited warranty does not cover any scratches or dents, corrosion or discolouring caused by heat, abrasive or chemical cleaners. Parts installed from other manufactures will nullify this warranty.

### 5 Year Limited Warranty

The following functional parts are included under this warranty: Burners, manifold assembly and carryover assembly.

### 3 Year Limited Warranty

The following functional parts are included under this warranty: Burners, manifold assembly and carryover assembly.

### 1 Year Limited Warranty

For one year from the date of original retail purchase Trileaf Distributions will replace any grill part that fails or is found to be defective to the degree of non-performance under normal household use, during the limited warranty period. Trileaf Distributions Ltd. are not responsible for any grill damage sustained during moving, storage, assembling or cleaning. Unless otherwise noted, as in above limitations, all components are covered for a period of one year.

**IMPORTANT: Should you have difficulty operating this product, or have a part that has become defective within the stated warranty period, DO NOT RETURN TO STORE. STORES DO NOT STOCK replacement PARTS AND ARE UNABLE TO HELP WITH TROUBLESHOOTING ADVICE. PLEASE CALL 1-877-707-5463. Have your Proof of purchase, serial number and model number available so that the customer support agent can be of assistance.**

**Purchaser:** By accepting delivery of this Barbecue the purchaser, hereby accepts the foregoing and expressly waives any other remedy and damages, direct, indirect, and consequential.

Online warranty registration now available. Visit [www.centroliving.ca](http://www.centroliving.ca)

---

## INSTALLATION INFORMATION

The installation of this appliance must be in accordance with all local codes, or in the absence of local codes:

- Canadian installation must conform to the current national standards, which at this time are CAN/CGA-B149.1/2-Natural Gas/Propane installation code.

---

## ADDITIONAL WARNINGS

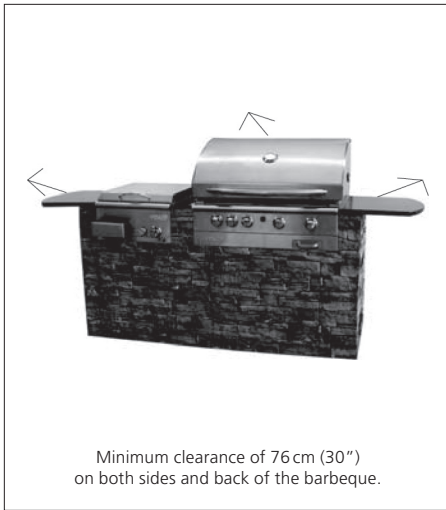

Drawing A

### Minimum clearance to adjacent combustible materials:

- **76 cm (30")** from furthest protruding edge on side of barbecue.
- **76 cm (30")** from furthest protruding edge on back of barbecue.

### See Drawing A

- Always keep the area around this barbecue clean and clear of any and all combustible materials such as gasoline or other inflammable liquids, paper or oily rags.
- **Do not** operate this barbecue under any overhanging or unprotected construction.
- Remember this barbecue is for **outdoor use only** and is **not** for use on any boat or recreational vehicle.
- Use this barbecue outdoors in a well-ventilated area and at least 3 m (10') from any dwelling or other building.
- **Do not** use in garages, or any other enclosed area.
- **Do not** leave your barbecue unattended while in operation.
- **Do not** obstruct the flow of combustion and ventilation air to the barbecue.
- **Do not** use while under the influence of drugs or alcohol.
- **Do not** store any spare L.P. (propane) cylinders, full or empty, under or near your barbecue.
- **Do not** allow children or pets to play anywhere near the barbecue.

---

## USE OF LP GAS CYLINDER

### Self-contained Propane Gas System

The self-contained (propane) gas system barbecue is designed to be used with only a 9.1 kg (20 lb) propane cylinder equipped with a type-1 cylinder valve. This barbecue **cannot** be connected to an existing #510 P.O.L. type valve cylinder (which has left-handed threads).

**Do not connect to a propane gas cylinder exceeding 9.1kg capacity or use a cylinder with any other type of cylinder valve connection device.**

The Type-1 valve can easily be recognized by the large external thread on the outside of the valve. Older existing valves **do not** have this outer external thread. Any attempt to connect a regulator to any connector other than the mating Type-1 connector (which comes with a large, black coupling nut such as the #510 P.O.L.) could result in fires, injuries or property damage, and could reduce the effectiveness of the important safety features built into the Type-1 system. Also connecting the #510 P.O.L. fitting to the cylinder will negate the flow control and the temperature shut-off features built into the new Type-1 connection system.

- The cylinder should not exceed 472 mm (18 1/2") in height and 317 mm (12 1/2") in diameter.

**When purchasing a cylinder for your barbecue, it must be constructed and marked as meeting the specifications of:**

- Canada: Transport Canada.

## DANGER

- NEVER store a spare LP tank under or near grill or in enclosed areas.

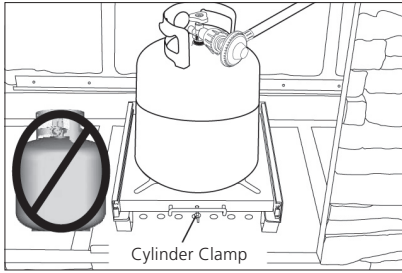

- Never fill the cylinder beyond 80% full.
- An overfilled or improperly stored tank is a hazard due to possible gas release from the safety relief valve.
- If you see, smell or hear escaping gas, immediately get away from the LP tank/grill and call your fire department.
- If the above is not followed exactly, a fire causing death or serious injury may occur.

## The Cylinder must also be equipped with:

- A shut-off valve with a correct cylinder valve outlet as specified in current standards.
- Canada: CAN/CGA 1.6g-M97 Outdoor Gas Grilles.
  - a) A safety relief valve with direct connection to the vapour space of the cylinder.
  - b) A collar to protect the tank shut-off valve.
  - c) A device for vapour withdrawal.
  - d) A ring on the bottom to secure the tank to its support assembly.
- Always turn off the cylinder valve completely when the barbecue is not in use.
- Always handle the tank valve with utmost care.
- Never connect an unregulated L.P. gas cylinder to the barbecue.
- Always keep the cylinder, in use, securely fastened in an upright position.

## WARNING

**Never store a spare cylinder, empty or full, near or under the barbecue when in operation.**

- Never store a spare cylinder, empty or full, near or under the barbecue when in operation.
- Never expose the cylinders to direct sunlight or excessive heat.
- Never insert any kind of object into the valve outlet as this may damage the backcheck; a backcheck that is damaged can leak, and a leaking propane cylinder can result in fires or explosions, property damage, severe injuries or death.

## TRANSPORTATION AND STORAGE OF THE LP CYLINDER

The propane cylinder is totally safe when handled properly, but if misused, the result could be an explosion or fire resulting in serious personal injury and/or property damage.

### To Avoid Unnecessary Risks

- Always recap the cylinder with the cap provided when not connected to the barbecue.
- **Do not** store the cylinder in any enclosed area such as a garage, and make sure the storage area has lots of ventilation.
- **Do not** store the cylinder near any appliances, or in any areas that may become hot, such as the trunk of a vehicle.
- Make sure the cylinder is out of reach of children.
- When transporting or storing the cylinder, make sure it is in an upright position and not on its side.
- **Do not** smoke around the cylinder, especially when transporting it in a vehicle.

## FILLING THE LP CYLINDER

The cylinder must be filled prior to use and must have the air purged. For safety, follow these instructions when having your cylinder filled:

- Have only your local qualified LP gas dealer fill or repair a cylinder.
- **Do not** overfill the cylinder beyond the safe 80% fill level.
- Make sure the dealer tests and checks the cylinder for leaks after filling.

## WARNING

**If the above instructions are not completely adhered to, it could cause a fire/explosion, resulting in death or serious injury, or property damage.**

## PRIOR TO USING

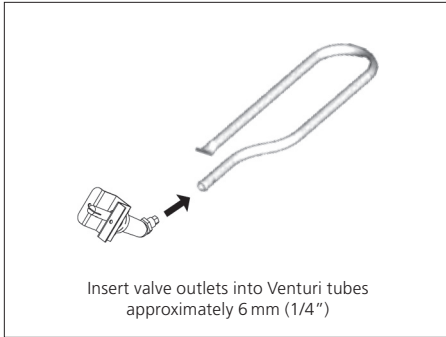

Drawing E

**Do not use your barbecue until you have carefully read and fully understand all the information in this manual. Please ensure the following:**

- Your barbecue is properly assembled.
- There are no leaks in the system (see "Leak Test").
- The burner is properly assembled, with the Venturi tubes seated over the valve outlets (Drawing E) and that there is nothing blocking the Venturi tubes (Drawing F).
- Ensure that all power cords and/or gas supply hoses will not touch or be near surfaces that will get hot.
- The barbecue is in a safe location (see Installation).

Ensure that the valve outlets (orifices) are assembled into the Venturi tubes approximately 6 mm (1/4") and that the valve outlets and Venturi tubes are approximately parallel to the bottom of the lower body.

## WARNING

### Natural Hazards Insects and Spiders

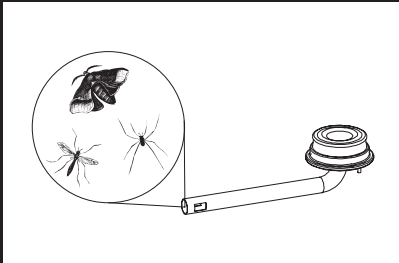

Drawing F

During shipment or storage, it's possible that small insects like spiders could find their way into the Venturi tubes and nest or make webs. This could block the flow of gas through the Venturi tube causing a smoky yellowish flame, or prevent a burner from lighting. It could even cause the gas to burn outside the Venturi tube, which could seriously damage your barbecue. If these occur, turn off the gas flow and wait for the barbecue to cool down. When the barbecue has cooled, remove the burner and clean out the Venturi tubes with a brush or pipe cleaner. Replace the burner and ensure that the Venturi tubes are seated over the orifice located on the gas valves. Cleaning the Venturi tubes should be conducted periodically, especially at the start of the season.

**Note:** Damage resulting from blocked Venturi tubes is not covered under the warranty.

**Orifice Size:** The orifice, in conjunction with the control valve, acts to regulate and restrict the amount of gas delivered to the burner. The hole size in the orifice varies by the gas supply pressure and by the BTU rating of the burner. Grills equipped for LP gas operate at a much higher gas pressure and therefore have a smaller size orifice.

### Hose and Regulator Inspection

**Adjustment:** The regulator is factory set at a specified outlet pressure of 11" of water column and is generally factory sealed and not adjustable. Do not try to adjust. The regulator can be checked by measuring the pressure with a manometer.

**Vent Hole:** There is a vent hole on top of the regulator. Check that it is clear of dirt and debris. If the hole is plugged, erratic and dangerous burning may result.

**O-ring Seal:** Before attaching the regulator to the cylinder, inspect the rubber O-ring on the P.O.L. fitting. Do not operate the grill if the O-ring is damaged or missing. Seal damage is common and we recommend replacement of the seal when the burner is replaced or when the seal is damaged. Cracks, splits or distortion will allow gas to escape. Additionally, the seal should be soft, pliable, and protrude slightly from the brass P.O.L. valve.

**Chew Marks:** The hose should be kept clean of grease and food drippings which attract squirrels and other animals. The animals will often eat the drippings on the hose and chew into the hose lining trying to get the last taste. Try cleaning the hose with an ammonia cleaner solution to minimize the attraction.

---

## SAFETY HOSE AND REGULATOR

**Propane Gas Models:** Your barbecue is designed to operate on L.P. (Propane) gas at a pressure of 2.74 Kpa (11" water column). A regulator preset to this pressure is supplied with the barbecue and must be used.

This regulator is equipped with the Type-1 quick-closing connecting system, which incorporates these safety features:

- Will not allow gas to flow until a positive seal has been made.
- Has a thermal component that will automatically shut off the flow of gas between 115-150°C (240-300°F).
- Has a flow limiting feature, which will restrict the flow of gas to 10 cubic feet/hour.

Should the large, black thermal-sensitive coupling nut be exposed to any extreme temperatures above 115°C it will soften and allow the regulator probe to disengage from the valve, and will shut off the gas. Should this occur, **do not** try to reconnect the nut; instead replace the whole regulator assembly with a new one (see the attached parts listing for details). The regulator probe also contains a flow-sensitive feature, which limits the flow of gas to 10 cubic feet/hour, in the event of a regulator malfunction or hose leak. If the flow control feature is activated, the cause of this excessive gas flow should be investigated and corrected before using the barbecue again.

**Note: Improperly lighting the barbecue can activate the flow control feature, resulting in lower heat output. If this occurs, the re-flow feature must be reset by turning all the burner controls and the cylinder valve off. Wait at least 30 seconds before slowly turning on the cylinder valve, and then after another 5 seconds turn the burner valve on and light the barbecue.**

- Never connect this barbecue to an unregulated propane gas supply, or to another kind of gas. **Do not** alter or change the hose or regulator in any way.
- Visually inspect the whole hose assembly before each use for evidence of wear or damage such as cracks, burns, or cuts. If any damage is found, replace the assembly before using the barbecue. Use only the recommended replacement hose.
- To avoid possible damage to the hose, **do not** allow any grease or other hot materials to fall on the hose, and make sure the hose does not contact any hot surfaces of the barbecue.
- The connection fitting must be protected when it's disconnected from the cylinder. **Do not** allow the fitting to bump or drag on the ground as nicks and scratches could help create a leak when connecting back to the cylinder.
- It is important to do the "Leak Test" procedure every time a cylinder is refilled or any of the components are changed, and especially at the beginning of a new season.

**Natural Gas Conversion Kit is available at Canadian Tire (Part# 85-1621-4)**

### To Reset The Gas Regulator Safety Device

1. Close the LP (propane) tank valve.
2. Turn all burner control knobs to the OFF position.
3. Disconnect the regulator from the LP tank.
4. Open the grill lid.
5. Open all of the control knobs to the high position.
6. Wait 2 minutes.
7. Close all of the control knobs.
8. Re-connect the regulator to the LP tank. Test for leaks.
9. With lid open, push in and turn the CENTER burner control knob to the HIGH position and then ignite the grill by pressing the Electronic Ignition button.
10. Once lit, close the grill lid.
11. Wait for 10 to 15 minutes for the Barbecue to preheat.

**ATTENTION: Proper start up and shut down procedures should be Followed to avoid regulator safety device activation.**

### WARNING

**If the heat output is too low, the flow control feature may have been activated by a gas leak. If so, turn off the burner valve and cylinder valve, and perform the "Leak Test". If there aren't any leaks, re-light the burner.**

## SAFETY

### LEAK TESTING

#### Perform a "Leak Test"

- Before lighting your barbecue for the first time.
- Every time the cylinder is refilled, or any component is replaced.
- At least once every year, preferably at the start of the season.

The "Leak Test" must be done outdoors, away from heat, open flames and flammable liquids. **Do not** smoke while performing the test. Use only a mixture of 50/50 liquid soap and water for leak testing. Never use a match or open flame.

#### The Following Must Be Checked

- The tank valve including the threads into the tank (Drawing C).
- All tank welds (Drawing B).
- Regulator fittings and tank connections (Drawing C).
- All hose connections (Drawing D).
- **With a newly filled and tested propane tank attached to the barbecue and all the barbecue controls turned "OFF", slowly open the cylinder valve one full turn.**
- **Using a brush and soap, soak all the connections and components listed above and shown in drawings B, C, D.**
- **Look carefully for bubbles forming, which is an indication of leaking gas.**
- **Tighten the connections at the bubbled areas until re-testing shows no indication of any leaks (shut off cylinder while correcting any leaks).**
- Shut off the cylinder valve and ensure all control valves are off.
- **Do not** use the barbecue if any leaks cannot be stopped. Turn off the gas cylinder valve, remove the gas cylinder and seek assistance from a qualified gas appliance service mechanic or gas dealer.

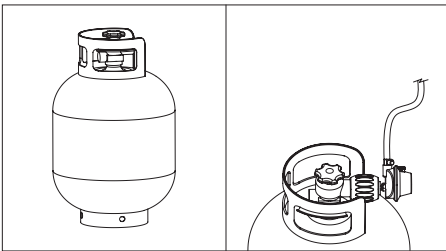

Drawing B

Drawing C

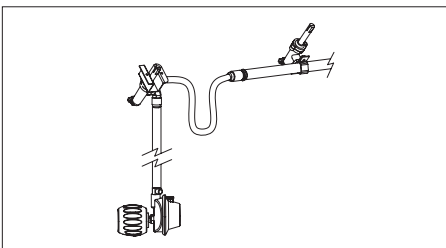

Drawing D

---

## LIGHTING THE GRILL

**Make Sure you have followed all the safety checks, procedures and instructions indicated in the previous section, before attempting to light the grill.**

### Lighting The Main Burners

1. Always open the hood completely and always inspect the grill and burners to confirm that all components are properly positioned before lighting the main burners.

#### WARNING

**Never stand with your head directly over the Barbecue when preparing to light the main burners, to prevent possible bodily injury.**

2. Always confirm that all of the burner control knobs are in the OFF position before opening the gas supply.
3. Slowly turn on the propane gas supply valve at the tank 1-2 turns.
4. Wait approximately 5 seconds before turning the CENTER burner Control knob to the HIGH position by pushing down on the knob and turning it counter-clockwise. This procedure allows pressure to stabilize, and prevents the flow limiting feature from being activated.
5. Immediately press the Electronic Igniter. You will hear a continuous clicking sound as the module generates a spark to the burner. The selected burner should light within 5 seconds. Light all remaining burners by pushing in and turning the corresponding control knob, to the HIGH position. Each burner will automatically ignite.

#### WARNING

**IF THE SELECTED BURNER DOES NOT LIGHT, immediately turn the burner control knob and cylinder valve to the OFF position, to prevent gas buildup. Wait five minutes for the gas to clear and then repeat the preceding starting procedure. IF the burner will not light when using the Ignitor, follow the match lighting instructions.**



6. Confirm that the burner is properly lit. If the flame pattern is other than normal, consult the Troubleshooting Guide for corrective action.
7. Always preheat the Barbecue before starting to cook. Light all burners and adjust them to the HIGH position for 5-10 minutes. Before placing any food on the Barbecue, clean the cooking grids with a Porcelain cleaning brush.
8. Adjust the controls to a medium setting for most cooking requirements. A light coating of cooking oil on the cooking grids, before heating the grill, will prevent foods from sticking to the grill.

### Turning The Burners Off

1. Always turn the burner control knobs to the off position when cooking has been completed.
2. Promptly turn OFF the gas supply valve at the propane cylinder.
3. Close the hood of the grill.

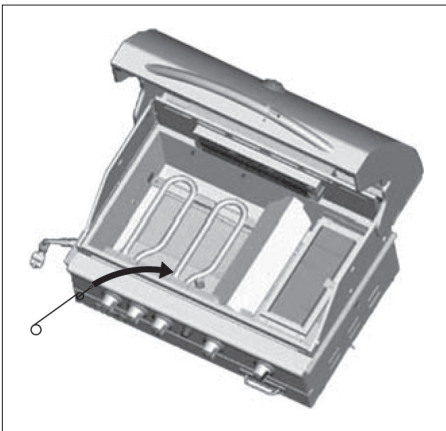

Drawing G

### Match Lighting The Main Burners

1. Open the BBQ lid before manual lighting your BBQ.
2. Confirm that all burner control knobs are in the off position before opening the Gas supply.
3. Remove cooking grates and remove the flame tamer from the far right burner (closest to the Sear Zone)
4. Always slowly open the propane tank gas valve approximately 1-2 turns
5. Place an ignited butane lighter or lit match near the burner port holes, approximately 1.25 cm (1/2") from the burner.
6. Push in and turn the corresponding main burner control knob to 'HIGH'. The burner should light immediately (within four seconds). If it does not turn off the control knob, extinguish the lighter or match, and wait 5 minutes for gas to clear.
7. Repeat steps. If burner still fails to light, refer to the Troubleshooting Guide to determine the cause and solution.
8. Once burner is lit, push in and turn all remaining main burner control knobs to HIGH. The unlit burners will light automatically.

### WARNING

**Never stand with your head directly over the Barbecue when preparing to light the main burners, to prevent possible bodily injury.**

### WARNING

**If the heat output is too low, the flow control feature may have been activated by a gas leak. If so, turn off the burner valve and cylinder valve, and perform the "Leak Test". If there aren't any leaks, re-light the burner.**

### Lighting the Side Burner

Use the Electronic Igniter on the main control panel and the Side Burner control knob, on the far left panel, to light the side burner.

- Push in and turn the side burner control knob to the HIGH position.
- Push the igniter button.
- If the burner does not light, turn the control knob to the OFF position and wait 5 minutes for the gas to clear.
- Repeat the above instructions. If the side burner still does not light, refer to the troubleshooting section for help or light the burner manually.

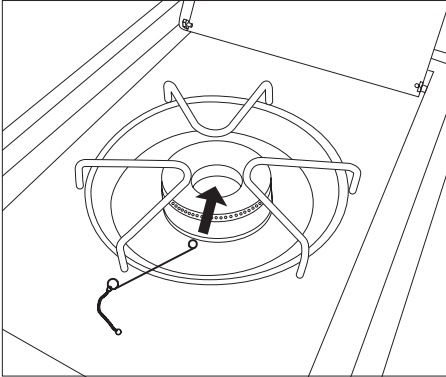

**Note:** The side burner is designed to accept a maximum weight of 20 lb. Do not overload the side burner.

### Lighting the Side Burner with a Match

- Place match in front ring of provided match holder.
- Place a lighted match through the hole to within 16 cm (1/2") of the side burner.
- Push in and turn the burner knob to the "HIGH" position. At this point, the burner should light, if it doesn't after 5 seconds, turn the control knob back to the "OFF" position and wait for the gas to clear.
- Wait 5 minutes, and then repeat the manual lighting procedure. If after three tries the burner still does not light, review the troubleshooting guide for help.

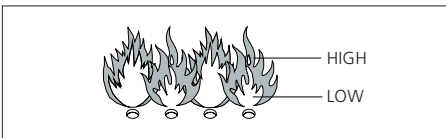

### Visually Check Burner Flame

Take off the grates and flame tamers. Light burners. Adjust the flame by turning the knobs from "HIGH" to "LOW". The flames will be smaller when the knobs are in the "LOW" position. Always check flame prior to each use. Perform flame check for side burner.

**SEAR ZONE  
OPERATING  
INSTRUCTIONS**

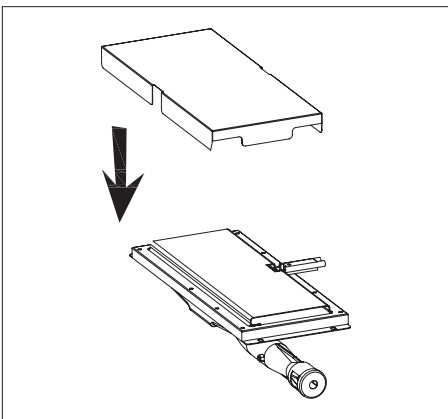
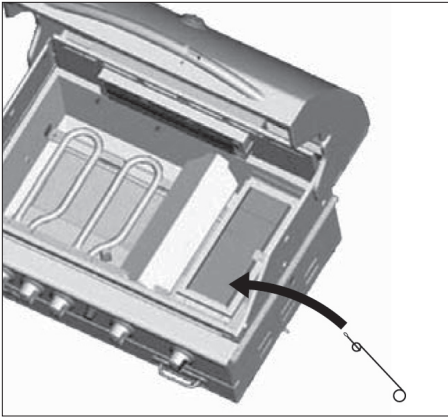
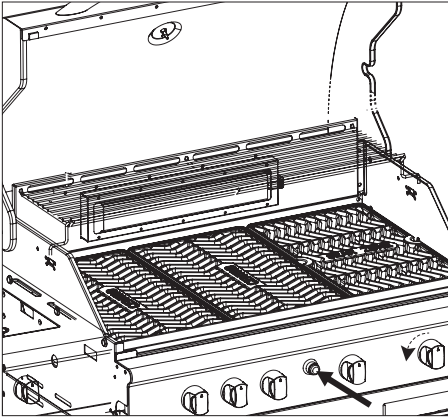

1. Follow all safety check and lighting procedures for lighting main burners.
2. Turn the infrared burner knob to HIGH position.
3. Push the igniter button until a clicking sound is heard to light the infrared burner.
4. **There is no low flame adjustment on this burner.**

**Match Lighting**

Follow the match lighting procedure used for the main burners on Page 7 of this manual to light the Sear Zone.

**When the BBQ is not in use, always cover the infrared burner with the Storage cover provided, to avoid burner damage caused by moisture or harsh weather. Purchase a Centro BBQ Cover to help protect your grill.**

**Operating the infrared burner**

1. **Always keep the BBQ lid OPEN** when the infrared burner is in use.
2. **Do not use the infrared burner and the rotisserie burner simultaneously.**
3. **This burner is FOR SEARING ONLY!! Not for cooking!!**
4. **DO NOT use this burner to cook FATTY MEAT.**

**Serious grease fire might take place.**

5. For steak or pork, sear each side for max 3 minutes to avoid from overcooking.

**See the Centro Grilling Guide for further maintenance, operating, troubleshooting, and cooking tips.**

**Natural Gas Conversion Kit is available at Canadian Tire (Part# 85-1621-4).**

---

## ROTISSERIE BURNER

### OPERATING INSTRUCTIONS

- Turn all knobs to “OFF”
- Open lid during lighting. Turn gas on at LP tank.
- Push in and turn the Rotisserie Burner Knob to the “ON” position.
- Push the Igniter. Be sure burner lights and stays lit.
- No temperature adjustment. Only ON and OFF.
- If the Igniter does not work, follow the match lighting instructions for the main burner on Page 7 of this manual.

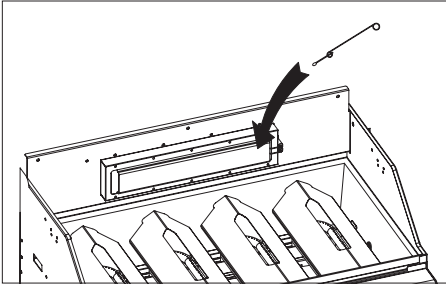

#### Match Lighting Procedure

- Open lid prior to lighting.
- Place an ignited lighter or lit match near the ports, approximately 1.25 cm (1/2”) from burner.
- Push in and turn the Rotisserie burner control knob to ‘HIGH’. The burner should light immediately (within four seconds). If it does not turn off the control knob, extinguish the lighter or match, and wait 5 minutes for gas to clear.
- Repeat steps 1 to 4. If burner still fails to light, refer to the Troubleshooting Guide to determine the cause and solution.

---

## TIPS ON USING YOUR ROTISSERIE

### Guide to Rotisserie Cooking

Rotisserie cooking produces foods that are moist and flavourful. Most commonly used for cooking meat or poultry, the rotisserie is designed to cook food slowly. You can place a cooking pan beneath the food to collect juices for basting and gravy. To flavour the contents of the cooking pan you may add herbs, onions, or other spices of your choice.

#### Balancing the Food

In rotisserie cooking, balancing the food is of utmost importance. The rotisserie must turn evenly or the stopping and starting action will cause the food to cook unevenly and possibly burn the heavier side.

The easiest foods to balance are those of uniform shape and texture. To test if the food is balanced correctly when secured, place the ends of the rotisserie spit loosely in the palms of your hands. If there is no tendency to roll, give the spit a quarter turn. If it is still stable, give it a final quarter turn. It should rest without turning in each of these positions. It can then be attached to your grill.

#### Food Preparation

When preparing poultry, truss the birds tightly so that wings and drumsticks are close to the body of the bird. The cavity of bird may be stuffed prior to this. Pull the neck skin down and, using a small skewer, fix it to the back of the bird. Push the rotisserie spit through lengthwise, catching bird in the fork of the wishbone. Centre the bird and tighten with the holding forks. Test the balance as described before.

A rolled piece of meat requires the rotisserie skewer to be inserted through the centre of the length of meat, then secured and balanced.

For meats that contain bones, it is best to secure the rotisserie skewer diagonally through the meaty section. If protruding bones or wings brown too quickly, cover with pieces of foil.



**PARTS LISTING FOR CENTRO 6000 SI BBQ AND MULTI-PURPOSE SIDE BURNER  
85-1620-6 PROPANE (G61501)**

| Item No. | Quantity | Specification                | Part No.     |
|----------|----------|------------------------------|--------------|
| A        | 1        | Top Lid Assembly             |              |
| AA       | 1        | Top Lid Weldment             | G615-0100-01 |
| AB       | 1        | Top Lid Handle               | G607-0001-01 |
| AC       | 1        | Thermometer                  | G413-0029-01 |
| AD       | 2        | Screw for Top Lid            | G607-0002-01 |
| B        | 1        | Burner Box Assembly          |              |
| BA       | 1        | Burner Box Weldment          | G610-0200-01 |
| BB       | 1        | Heat Shield A                | G615-0020-01 |
| BC       | 1        | Left Side Upper Panel        | G615-0200-01 |
| BD       | 1        | Right Side Upper Panel       | G615-0300-01 |
| BE       | 1        | Rotisserie Burner            | G610-6000-01 |
| BF       | 1        | Backburner Brace B           | G610-0017-01 |
| BG       | 1        | Wind Shield, Rotisserie      | G502-0095-01 |
| BH       | 1        | Burner Brace                 | G607-0006-02 |
| BI       | 2        | Main Burner - A              | G502-1700-01 |
| BJ       | 1        | Main Burner - B              | G502-1900-01 |
| BK       | 1        | Sear Zone Burner             | G610-5000-01 |
| BL       | 3        | Flame Tamer                  | G607-0005-01 |
| BM       | 1        | Infrared Burner Rain Shield  | G610-0013-01 |
| BN       | 2        | Cooking Grate - A, Burnerbox | G610-0002-01 |
| BO       | 1        | Cooking Grate - B, Burnerbox | G610-0003-01 |
| BP       | 1        | Warming Rack                 | G610-0001-01 |
| BQ       | 4        | Upper Brace                  | G615-0013-01 |
| BR       | 1        | Match Holder                 | G608-0019-01 |
| BS       | 1        | Rotary Ignition Kit          | G105-0018-01 |

| Item No. | Quantity | Specification                                  | Part No.     |
|----------|----------|--|--------------|
| CA       | 1        | Manifold Assembly (w/ main & rotisserie valve) | G615-4800-01 |
| CB       | 1        | Regulator                                      | G602-0050-01 |
| CC       | 1        | PVC Hose A, Sideburner                         | G615-0005-01 |
| CD       | 1        | PVC Hose B, Sideburner                         | G615-0007-01 |
| CE       | 1        | Sideburner Valve                               | G615-0006-01 |
| CF       | 1        | Rotisserie Flexible Hose w/ Nozzle             | G615-0021-01 |
| CG       | 1        | Electronic Ignition Kit                        | G502-0066-02 |
| CH       | 1        | Electrode w/ Wire f/ Main Burner               | G607-0008-01 |
| CI       | 1        | Control Panel                                  | G610-0054-01 |
| CJ       | 6        | Control Knob Bezel                             | G419-0006-01 |
| CK       | 5        | Control Knob                                   | G610-0015-01 |
| CL       | 1        | Control Knob, Sear Zone                        | G610-8300-01 |
| CM       | 1        | Left Rail, Grease Tray                         | G615-0009-01 |
| CN       | 1        | Right Rail, Grease Tray                        | G615-0010-01 |
| CO       | 1        | Upper Rear Panel                               | G615-0008-01 |
| CP       | 1        | Grease Tray                                    | G610-6400-01 |
| CQ       | 1        | Heat Shield, Tank                              | G615-0011-01 |
| CR       | 1        | Front Brace                                    | G615-5000-01 |
| CS       | 1        | Electronic Ignition Button                     | G409-0030-01 |
| D        | 1        | Side Burner Shelf Assembly                     |              |
| DA       | 1        | Sideburner Lid                                 | G615-0500-01 |
| DB       | 2        | Sideburner Lid Handle                          | G607-0040-01 |
| DC       | 1        | Sideburner Griddle                             | G615-0018-01 |
| DD       | 1        | Sideburner Grate                               | G615-0017-01 |
| DE       | 1        | Sideburner Rear Panel                          | G615-0014-01 |
| DF       | 1        | Sideburner Kit                                 | G615-0600-01 |
| DG       | 1        | Electrode w/ Wire f/ Sideburner                | G105-0012-01 |
| DH       | 1        | Sideburner Hosing                              | G615-6100-01 |
| DI       | 1        | Condiment Basket                               | G615-0016-01 |
| DJ       | 1        | Sideburner Bracket                             | G615-0015-01 |
| DK       | 1        | Pull Out Tank Tray                             | G615-8000-01 |
| DL       | 1        | Instruction Manual                             | G615-M001-01 |
| DM       | 1        | Hardware Pack                                  | G615-B001-01 |

**ENTERTAINMENT ISLAND CENTRO 6000SI BARBECUE**  
**85-1620-6 PROPANE (G61501)**

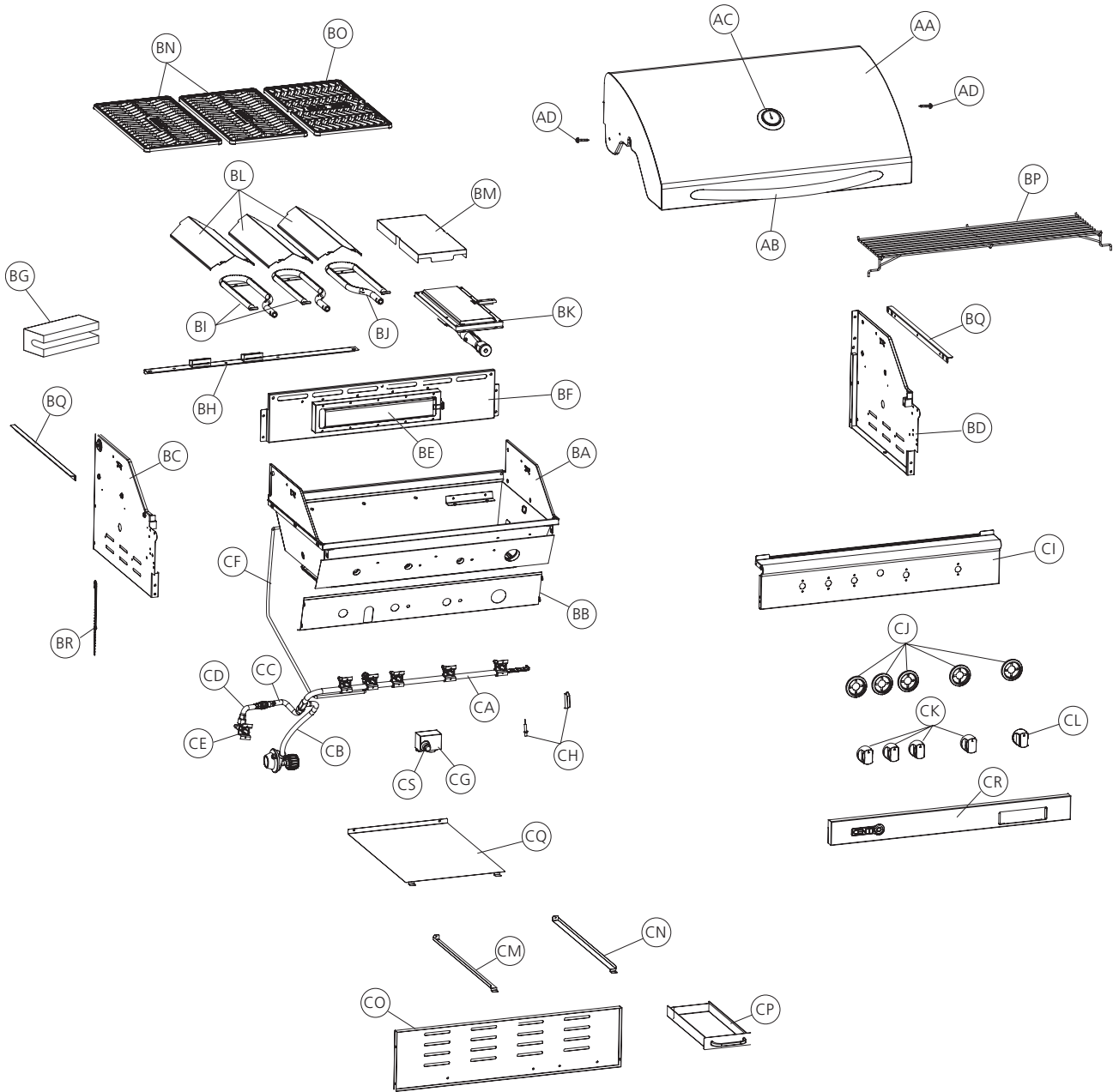

**ENTERTAINMENT ISLAND MULTI PURPOSE SIDE BURNER  
85-1620-6 PROPANE (G61501)**

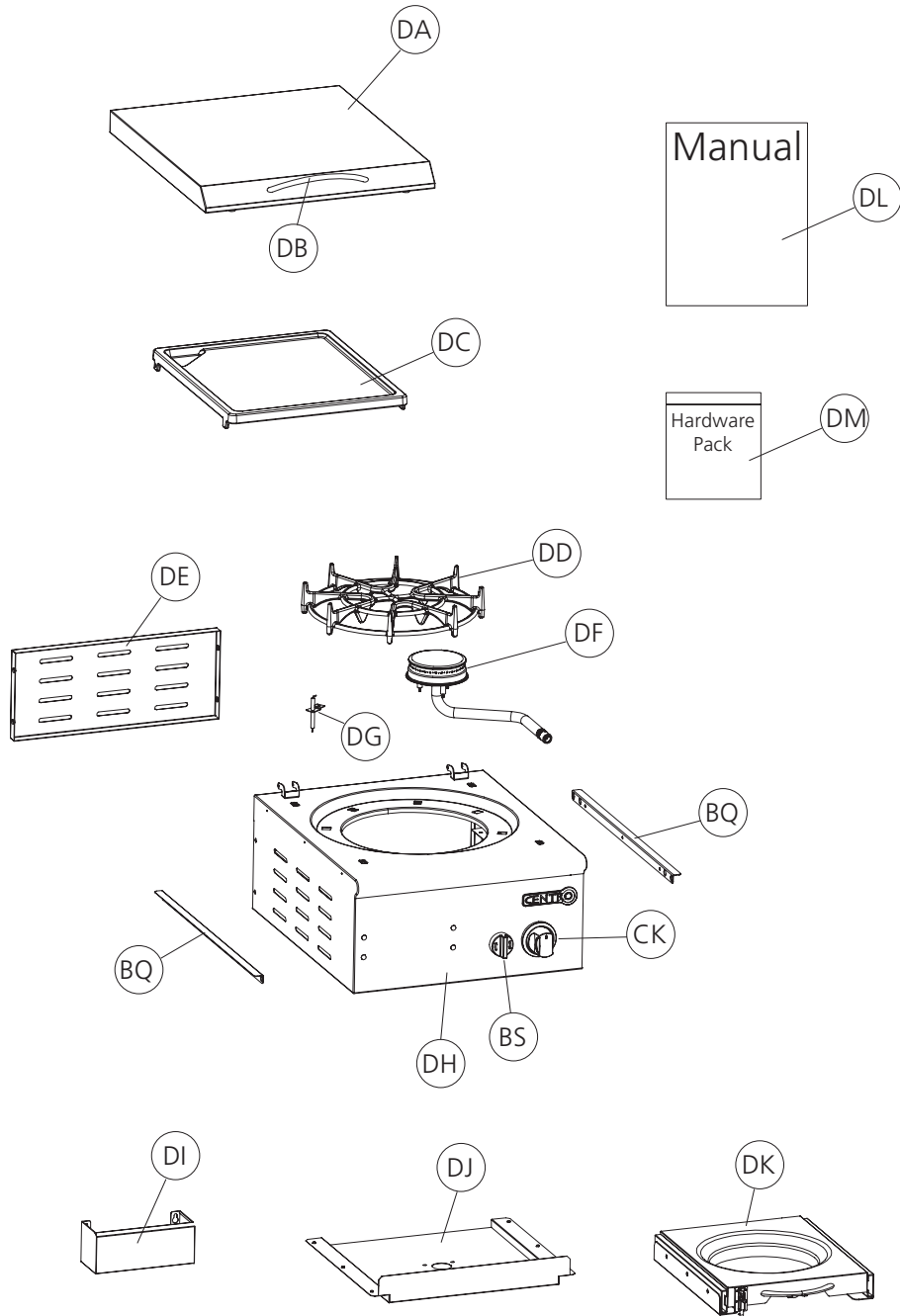



# CENTO 6000 SI BBQ AND MULTI-PURPOSE SIDE BURNER

## ASSEMBLY INSTRUCTIONS

### Tools Needed for Assembly

- 1/4" and 5/16" crossed screwdriver
- Adjustable wrench
- Pliers
- Rubber mallet

Before assembling the barbecue, read these instructions carefully. Assemble the barbecue on a flat, clean surface. Grill is heavy. You should have two people assemble the barbecue together.

**Notes: Do not fully tighten all the nuts during this initial stage.**

**Caution: Sheet metal can cause injury. Wear gloves when installing the grill. Use care when assembling.**

### Hardware Pack List

| No. | Description               | Quantity |
|-----|---------------------------|----------|
| 1   | 1/4-20UNC x 13 Screw      | 6        |
| 2   | ø7 Lock Washer            | 6        |
| 3   | ø7 Washer                 | 6        |
| 4   | 1/4-20UNC x 35 Wing Screw | 4        |
| 5   | AA Battery                | 1        |

**Before assembling please note:**  
**Natural Gas Conversion Kit is available at Canadian Tire (Part# 85-1621-4).**



**PARTS LISTING FOR  
ENTERTAINMENT  
ISLAND AND GRANITE  
COUNTER TOP  
85-1620-6 (PROPANE)  
(G61501)**

| <b>Item No.</b> | <b>Quantity</b> | <b>Specification</b>                 | <b>Part No.</b> |
|-----------------|-----------------|--------------------------------------|-----------------|
| EA              | 1               | Top Rear Granite Support Brace       | G615-0061-01    |
| EB              | 1               | Rear Island Wall                     | G615-0055-01    |
| EC              | 1               | Center Granite Countertop            | G615-0064-01    |
| ED              | 1               | Top Support Bar                      | G615-0056-01    |
| EE              | 2               | Granite Side Shelf                   | G615-0065-01    |
| EF              | 4               | BBQ & Sideburner Support Bars        | G615-0059-01    |
| EG              | 1               | Wire Brace                           | G615-0052-01    |
| EH              | 1               | Tank Exclusion, Wire Frame           | G615-0060-01    |
| EI              | 1               | Right Island Wall                    | G615-0054-01    |
| EJ              | 2               | Shelf Support Bracket                | G615-0066-01    |
| EK              | 4               | Bottom Support Feet                  | G615-0051-01    |
| EL              | 1               | Bottom Panel                         | G615-0050-01    |
| EM              | 1               | Front Island Wall                    | G615-9100-01    |
| EN              | 1               | Right Door                           | G615-0070-01    |
| EO              | 1               | Paper Towel Holder                   | G615-0071-01    |
| EP              | 1               | Left Door                            | G615-0067-01    |
| EQ              | 1               | Trash Basket                         | G615-0068-01    |
| ER              | 1               | Wire Handle for Trash Basket         | G615-0069-01    |
| ES              | 1               | Top Front Granite Support Brace      | G615-0062-01    |
| ET              | 1               | Left Island Wall                     | G615-0053-01    |
| EU              | 1               | Support Bracket                      | G615-0063-01    |
| EV              | 1               | Hardware Pack - Entertainment Island | G615-8001-02    |

ENTERTAINMENT ISLAND WITH GRANITE COUNTER TOP  
85-1620-6 (PROPANE) (G61501)

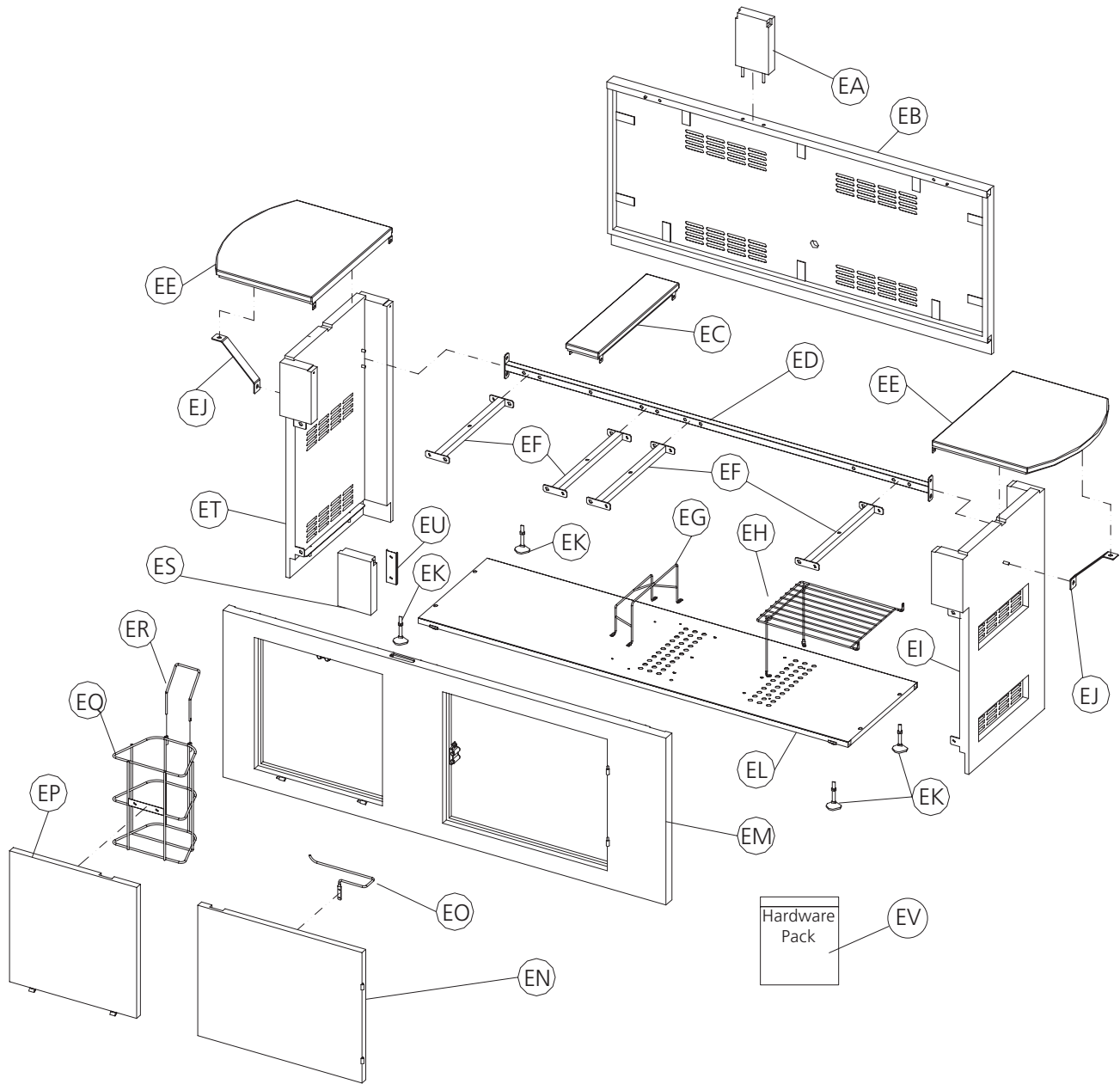

# ENTERTAINMENT ISLAND AND GRANITE COUNTER TOP

## ASSEMBLY INSTRUCTIONS

### Tools Needed for Assembly

- 1/4" and 5/16" crossed screwdriver
- Adjustable wrench
- Pliers
- Rubber mallet

Before assembling the barbecue, read these instructions carefully. Assemble the barbecue on a flat, clean surface. **Grill is heavy. You should have two people assemble the barbecue together.**

**Notes: Do not fully tighten all the nuts during this initial stage.**

**Caution: Sheet metal can cause injury. Wear gloves when installing the grill. Use care when assembling.**

### Hardware Pack List

| No. | Description            | Quantity |
|-----|------------------------|----------|
| A   | 5/16-18UNC x 38 Screw  | 2        |
| B   | 5/16-18UNC x 20 Screw  | 10       |
| C   | 5/16-18UNC Nut         | 26       |
| D   | ø8 Washer              | 38       |
| E   | ø8 Lock Washer         | 38       |
| F   | 1/4-20UNC x 15 Screw   | 13       |
| G   | ø6 Washer              | 13       |
| H   | ø6 Lock Washer         | 13       |
| I   | No. 8-32UNC x 10 Screw | 10       |
| J   | ø4 Washer              | 10       |

**Before assembling please note:  
Natural Gas Conversion Kit is available at Canadian Tire (Part# 85-1621-4).**

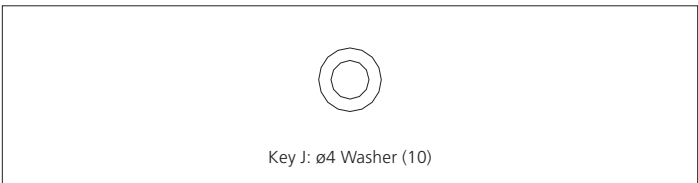
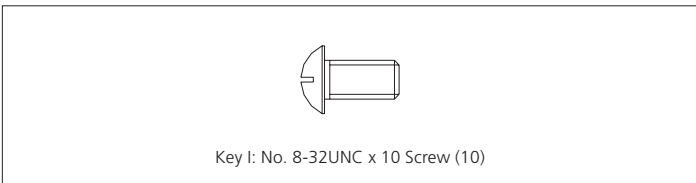
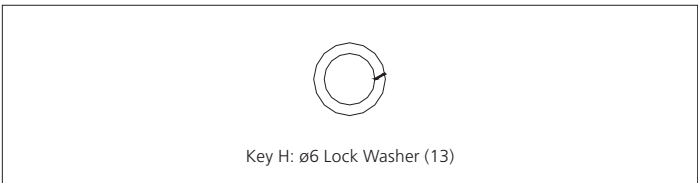
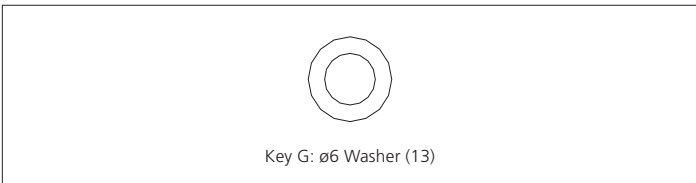
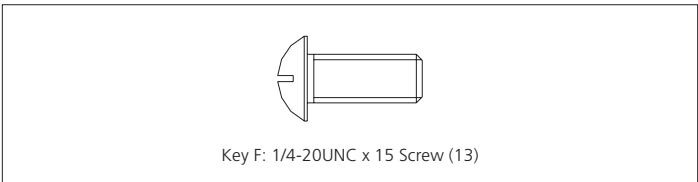
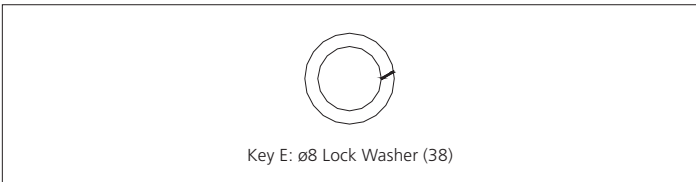
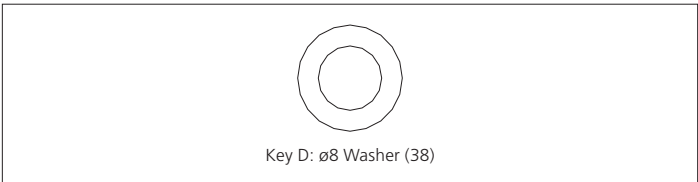
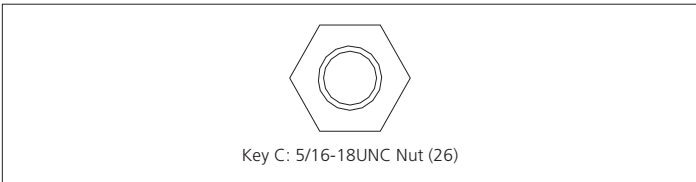
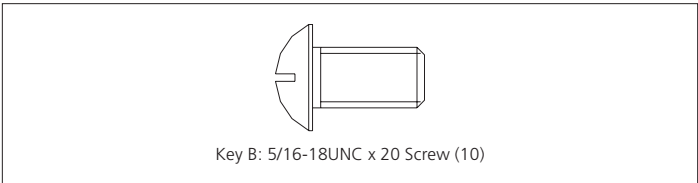
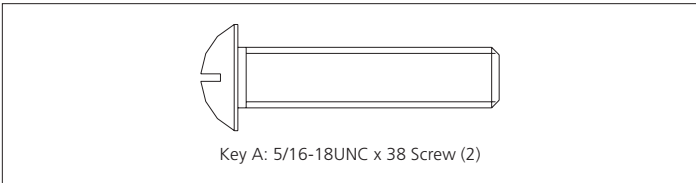

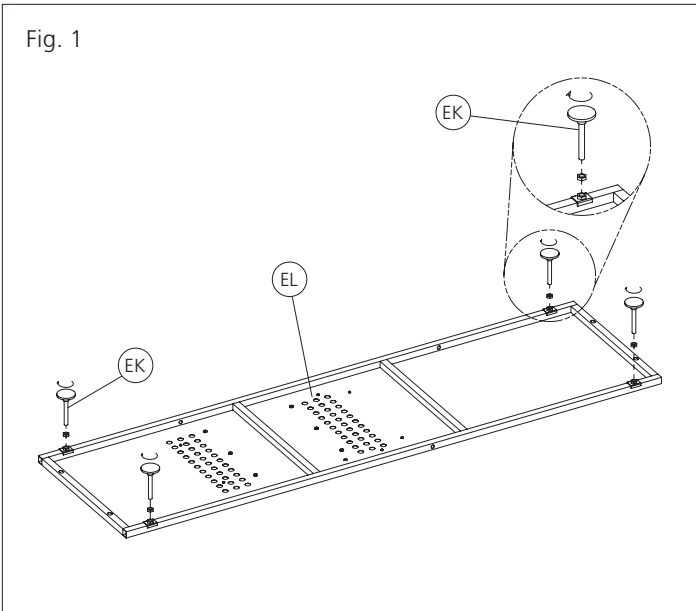

**Note: Hardware for Steps #1-21 are provided in the Entertainment Island with Granite Countertop hardware pack.**

# 1

Assemble the Bottom Support feet (EK) (x4) and Nut (x4) to the Bottom Panel (EL) as shown. Tighten all bolts. Turn Bottom Panel over.

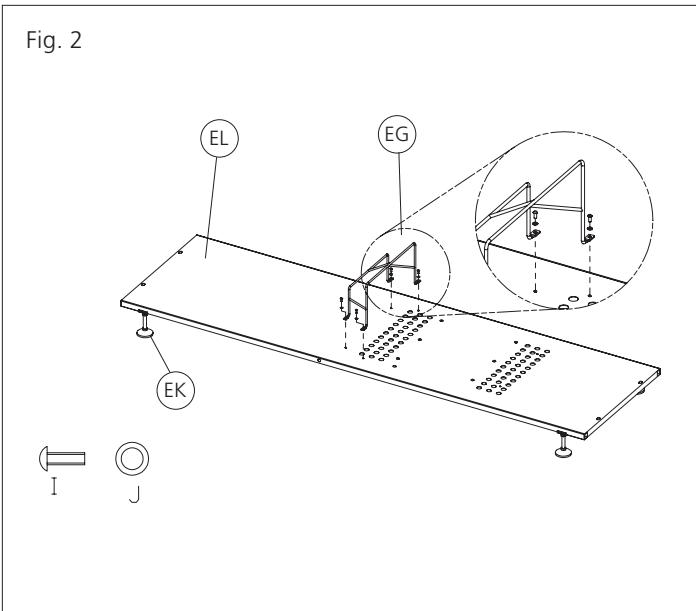

# 2

Assemble the Wire Brace (EG) to the Bottom Panel (EL) using hardware parts I & J.

Put the Bottom Panel assembly (EL) aside until Step 6.

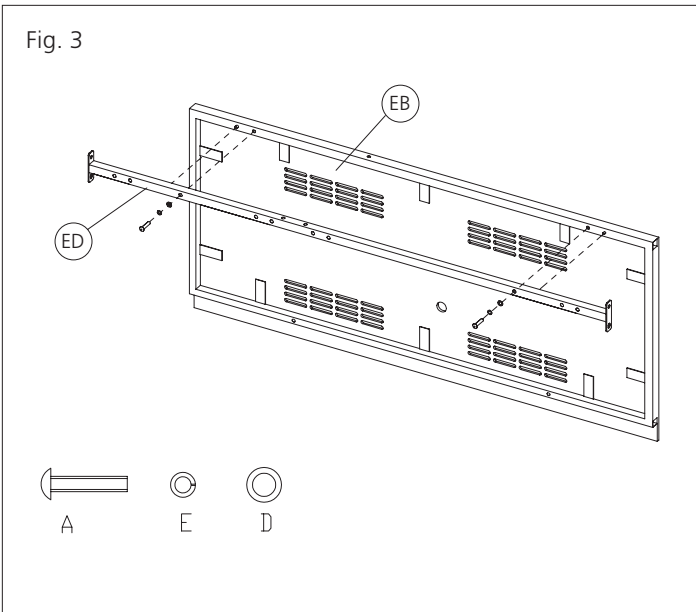

# 3

Assemble the Top Support Bar (ED) to the Rear Island Wall (EB) using hardware A, D, and E.

# 4

Align and connect the Left (ET) and Right (EI) Island Walls to the Top Support Bar (Ed) using Hardware C, D, and E as shown.

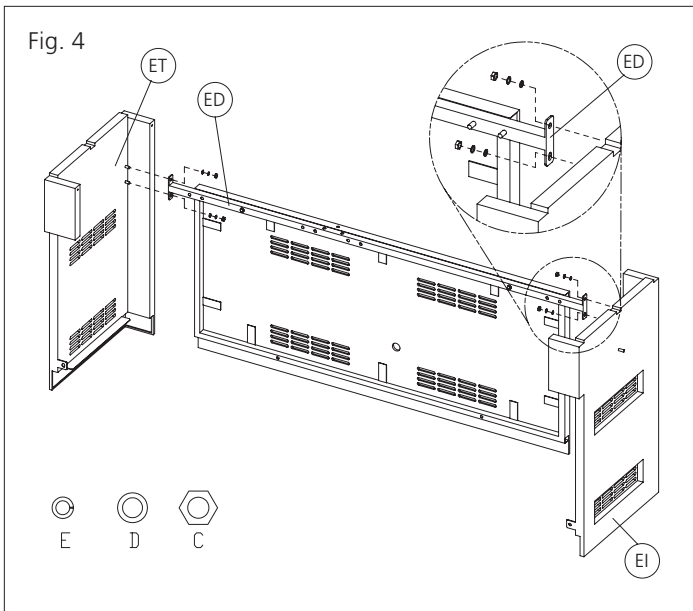

# 5

Align and connect the Front Island Wall (EM) to the Left and Right Island Walls (ET + EI) using Hardware B, C, D, E as shown.

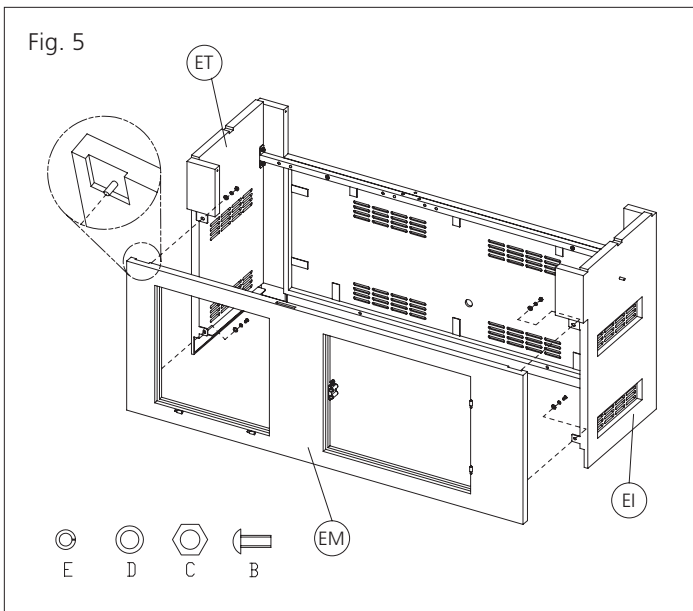

# 6

Invert the entire Entertainment Island Cart in this step to assemble the Bottom Panel (EL). **At least two people are recommended for this and all assembly steps.** Align the Bottom Panel (EL) to the bottom of the Entertainment Island Cart.

**Note:** Bottom Panel air vents should be on the right side of the Island Cart.

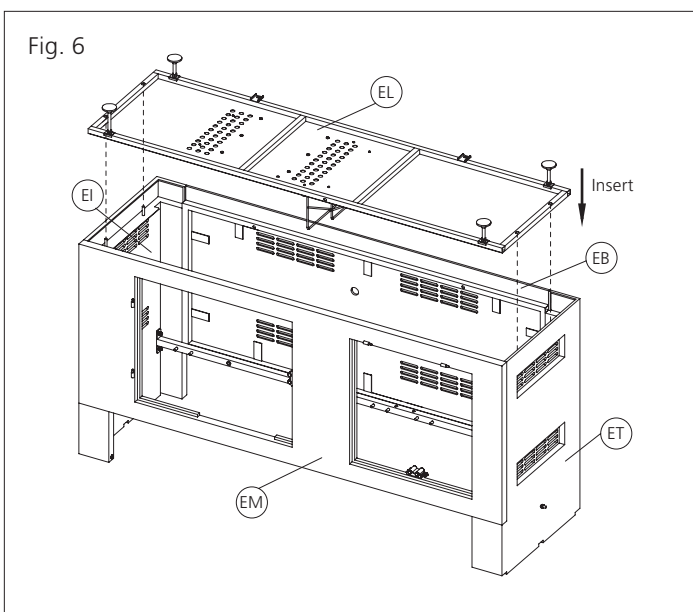

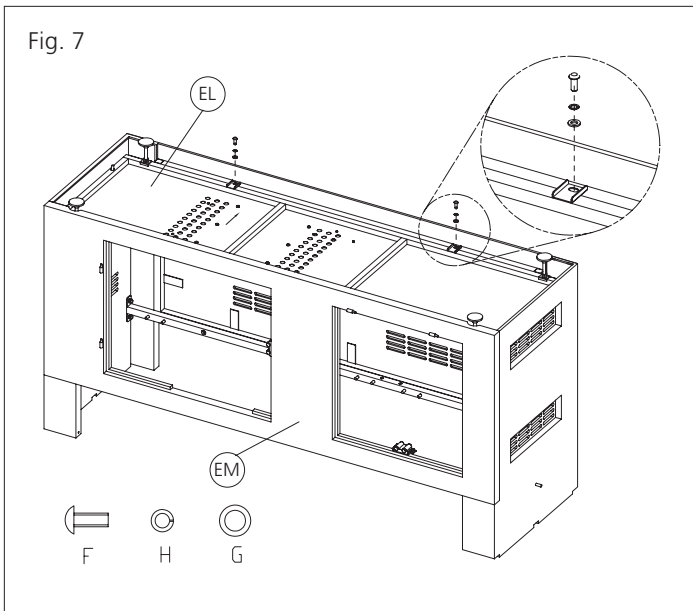

# 7

Assemble the Bottom Panel (EL) by using Hardware F, G, and H.

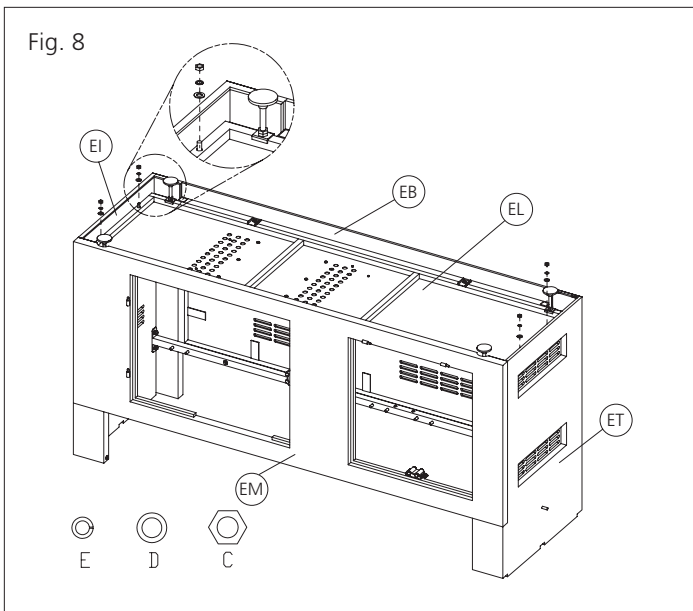

# 8

Once the Bottom Panel (EL) has been attached to the Front and Rear Island Walls (EM + EB), you can now attach the Bottom Panel (EL) to the Left and Right Island Wall (ET + EI) using Hardware C, D, and E. Once all assembly has been completed, you can now turn the Entertainment Island upright.

Attention: Please ensure the unit is well supported from both sides and the centre to avoid damage.

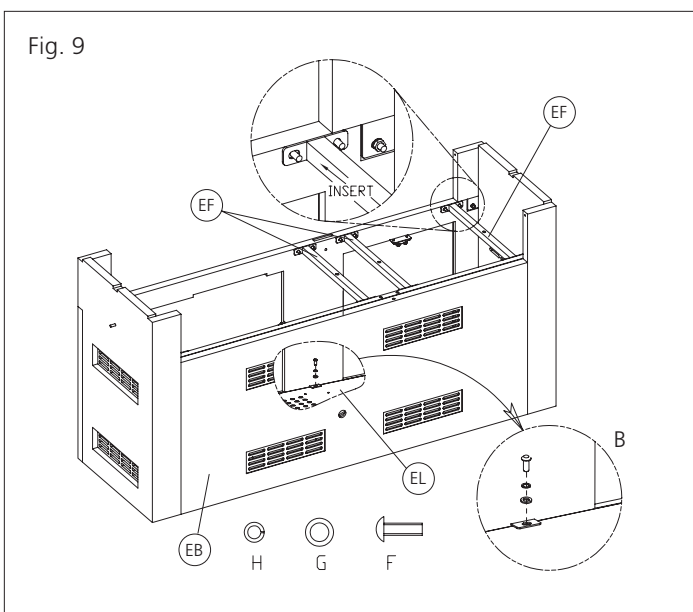

# 9

A. Position the BBQ and Side Burner support bar (EF) into the Island as shown. (rear-view assembly image).

B. Using hardware F, G and H attach the bottom panel (EL).

# 10

Connect the BBQ and Side Burner support bars (EF) to the rear island wall (EB) using hardware D, E and B.

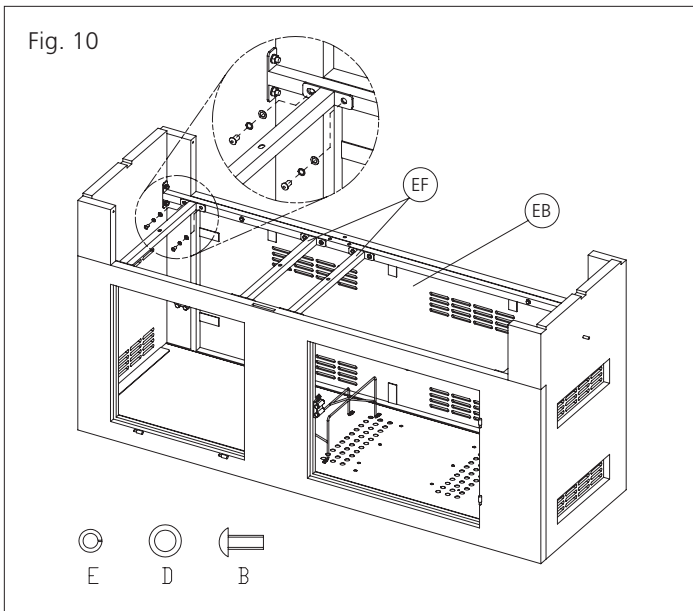

# 11

Connect the front BBQ and side burner support bars (EF) to the front Island wall (EM) using hardware D, E and C.

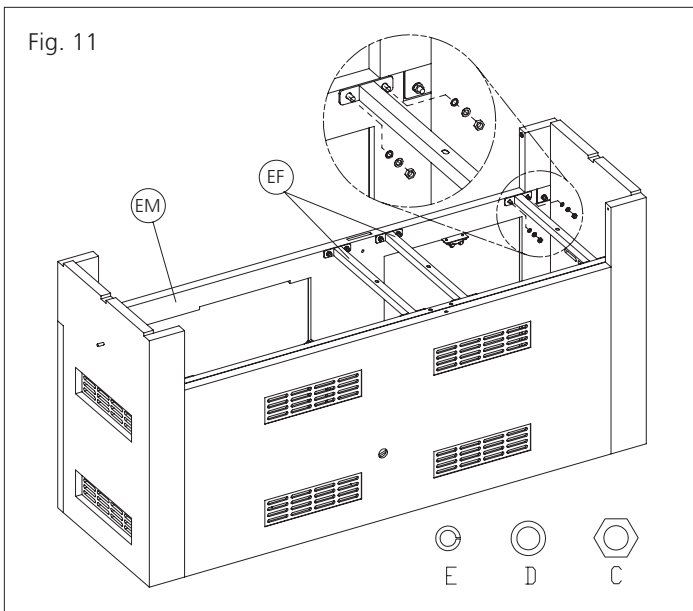

# 12

Assemble the Tank Exclusion wire frame (EH) to the inside of the Right Island Wall (EI) and Bottom panel (EL) using hardware I and J.

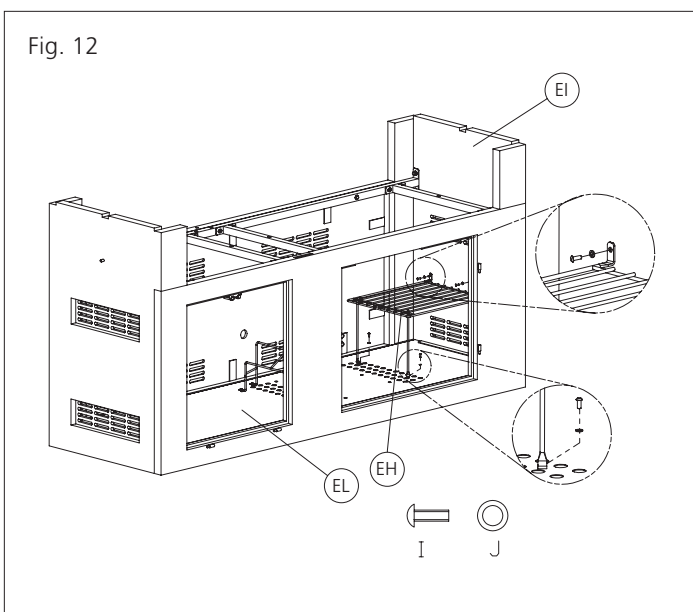



# 13

Insert and Attach the Top rear granite support brace (EA) to the Rear Island Wall (EB) using hardware C, D and E.

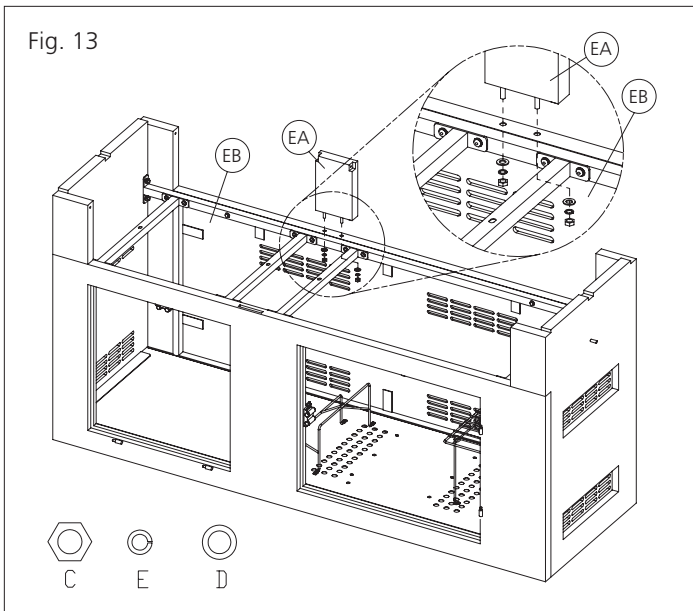

# 14

Insert and attach the Top Front Granite Support brace (ES) to the Front Island Wall (EM), together with the Support Bracket, as shown using hardware F, G and H. (Image shown is a rear view).

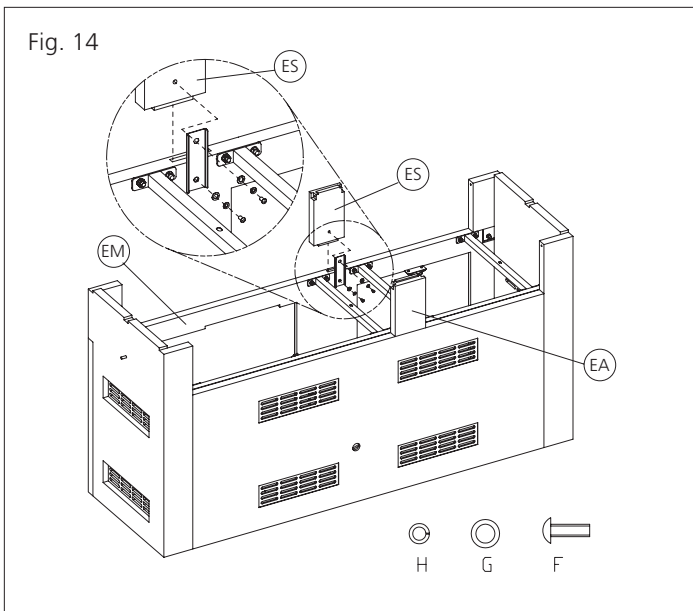

# 15

Mount the Center Granite counter top (EC) to the Top Front and Rear Support braces (ES + EA), as shown using hardware H, G, and F.

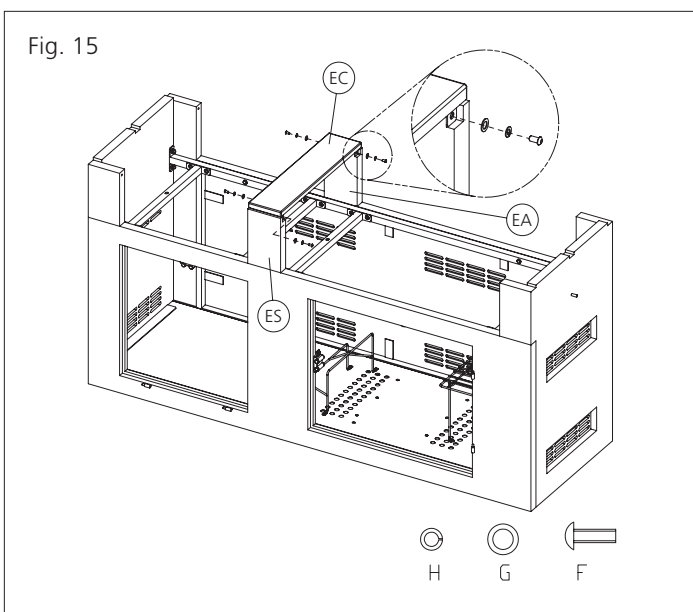

# 16

Mount the Left granite Side Shelf (EE) to the Left Island Wall (ET) using the Shelf Support Bracket (EJ) and hardware C, D, E, F, G and H, as shown.

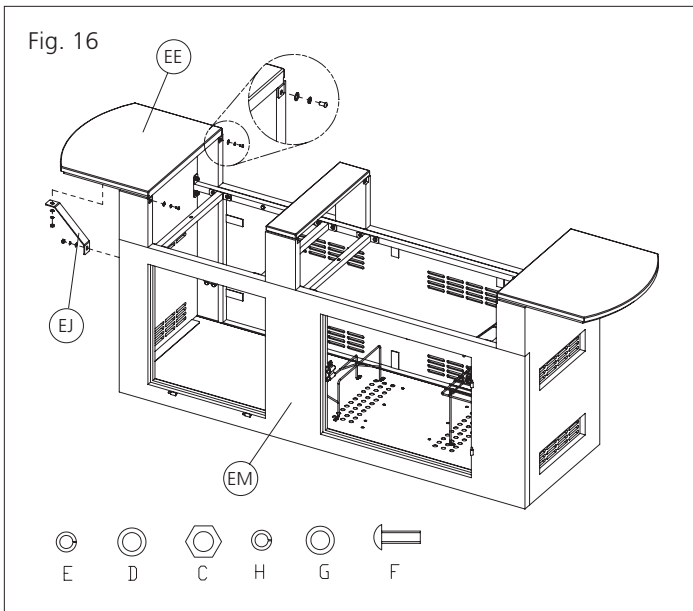

# 17

Attach the Trash Basket (EQ) to the Left Door (EP) using hardware D, E and C.

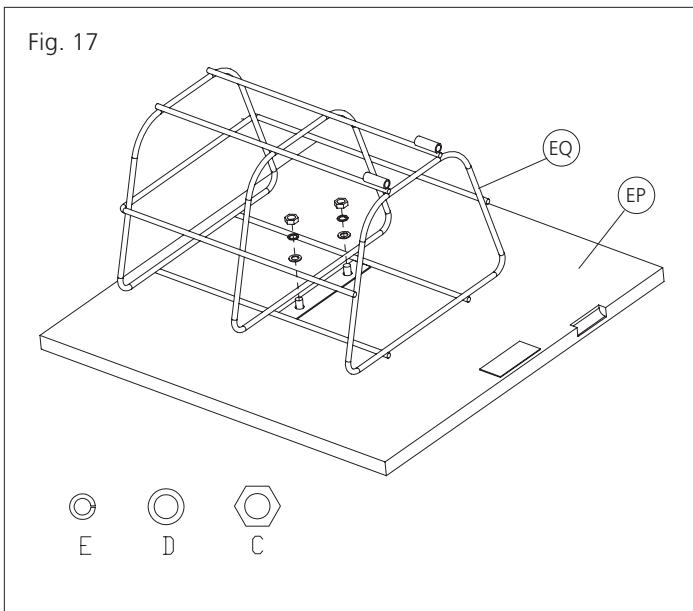

# 18

Attach the paper Towel Holder (EO) to the inside of the Right Door (EN) as shown, using hardware I and J.

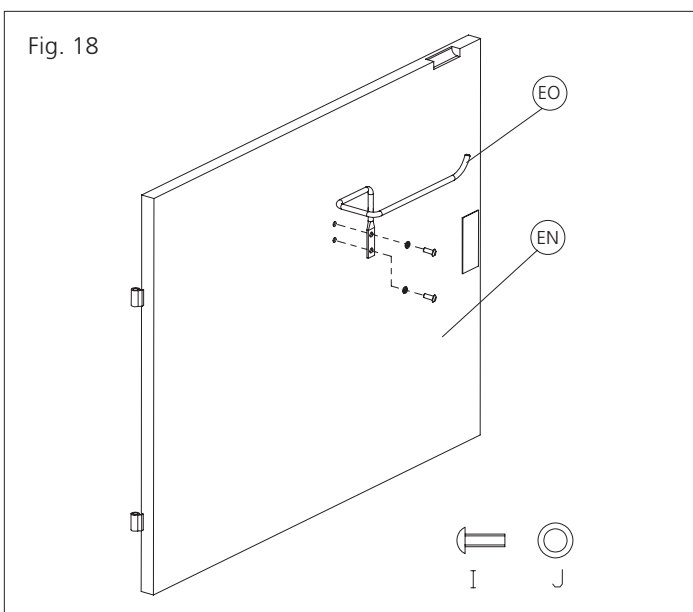
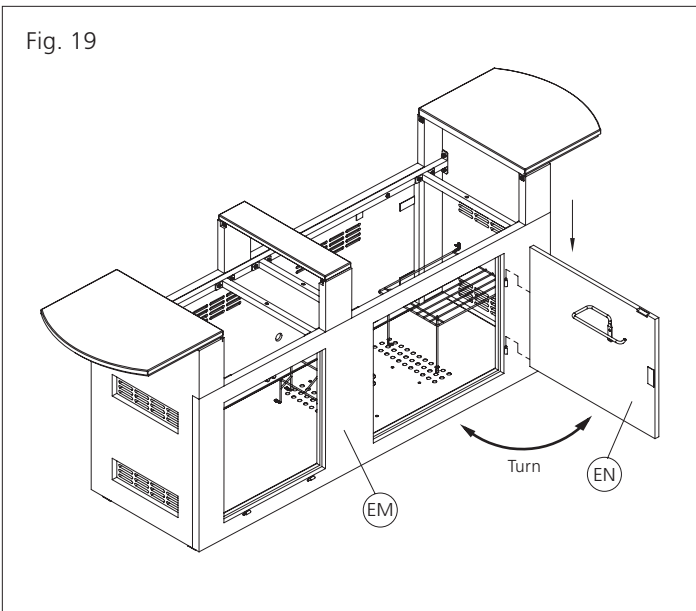

Fig. 19



# 19

Assemble the right door (EN) to the Front Island Wall (EM) by sliding the door into the hinges from the top as shown. No hardware is needed in this step.

Fig. 20

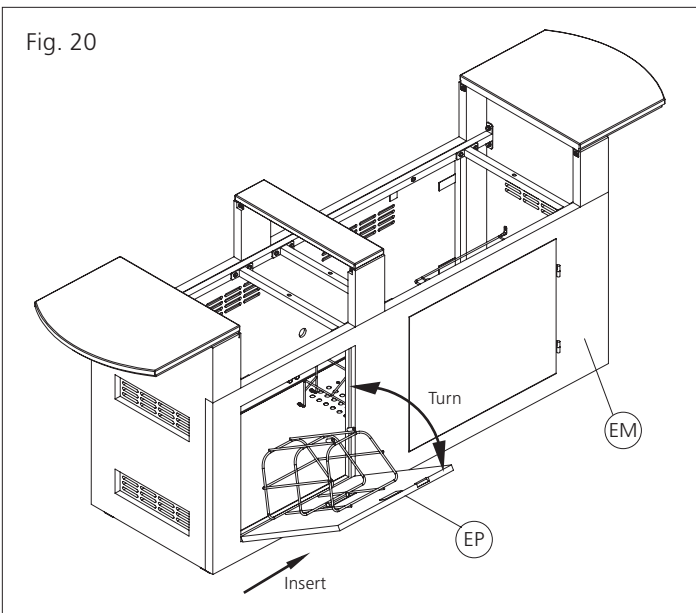

# 20

Assemble the Left Door (EP) to the lower hinges by sliding the door into the hinges from left to right, as shown. No hardware is needed in this step.

Fig. 21

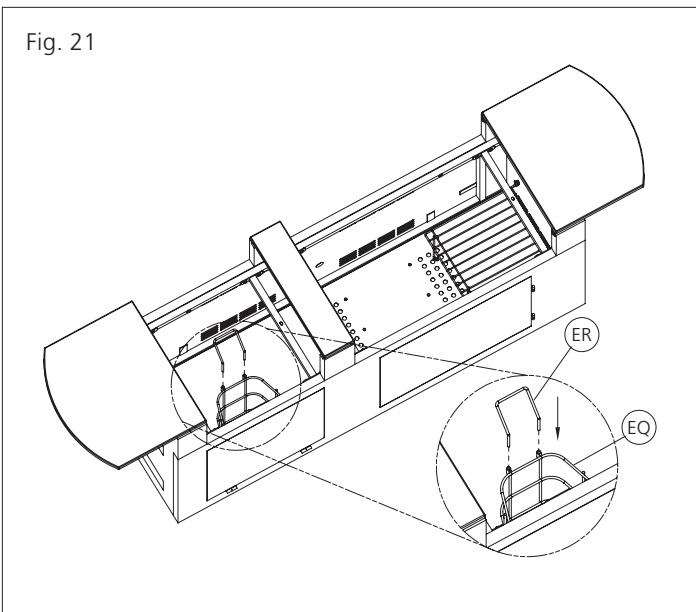

# 21

Attach the Wire Handle for Trash Basket (ER) to the top of the Trash Basket (EQ). No hardware is needed in this step.

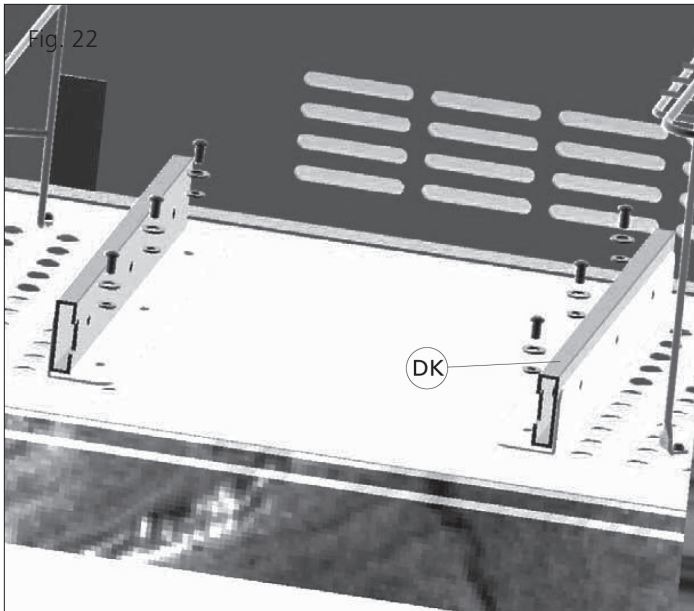

Hardware for Steps 22-24 are provided in Centro 6000 SI BBQ and Multi-purpose Side Burner hardware pack.

# 22

Assemble the 2 tracks of Pull-out Tank Tray (DK) to the bottom panel (located inside the right door) by using 1/4"-20UNC x 13 screw (x6), 7mm flat washer (x6), and 7mm lock washer (x6), as shown. Then insert the body of the Pull-out Tank Tray into the tracks.

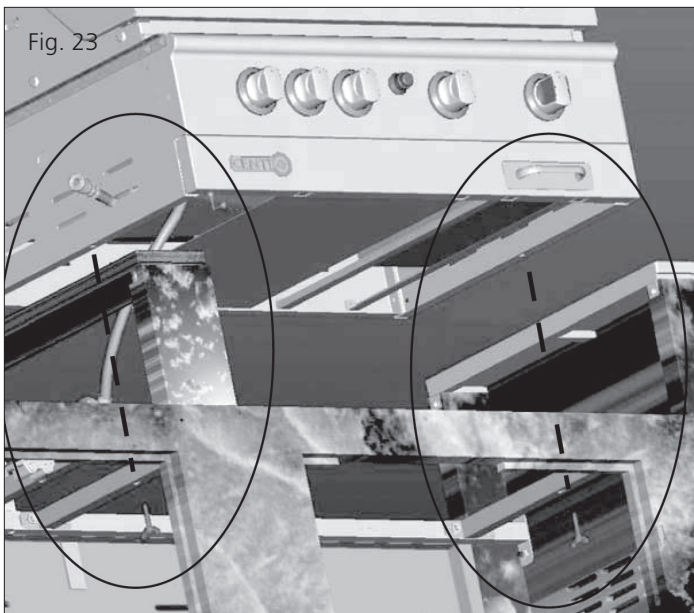
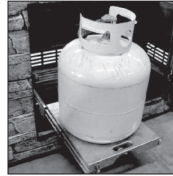

# 23

Place the main grill head onto the 2 BBQ Support bars of the Entertainment Island on the right. Secure the grill head to the 2 supporting bars by 2 wing screws as shown.

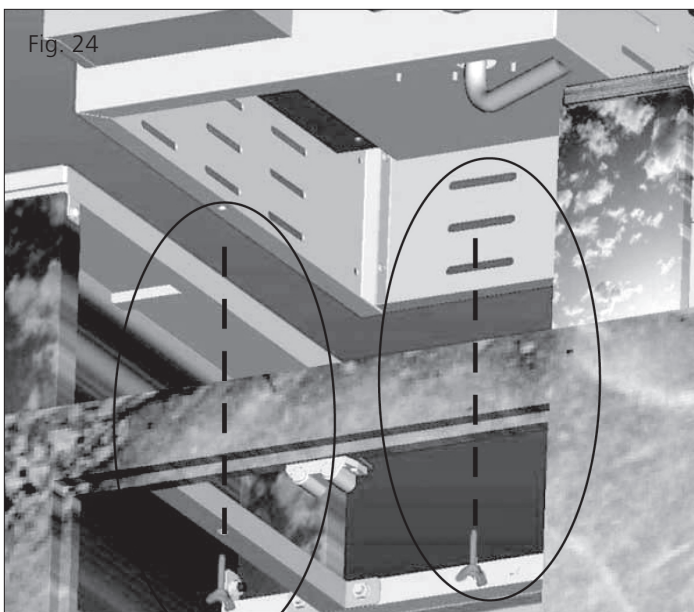

# 24

Place the Multi-purpose Side Burner onto the 2 Side Burner Supporting bars at the left side of the Entertainment Island. Secure the side burner to the 2 supporting bars by 2 wing screws as shown.

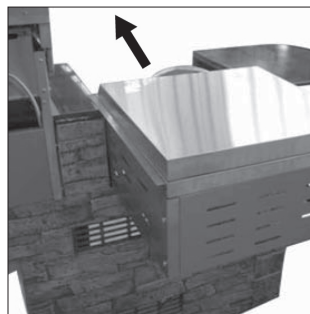

**Important**

Insert the Side Burner from back. Be careful the interference between the PVC hose (CD) and stone base.

# 25

Connect the female and male ends of the QDD device found under the main grill head and Side Burner. Follow by connecting the Hose and Regulator to the Propane tank.

Make sure the hose and regulator will pass through the front gap between the front panels and grill body.

Secure 20lb propane tank onto the bottom shelf base of the cart as shown. Attach the regulator valve to 20lb propane tank.

## WARNING

Do not store an extra tank inside the Entertainment Island Cart.

Natural Gas Conversion Kit is available at Canadian Tire (Part# 85-1621-4).

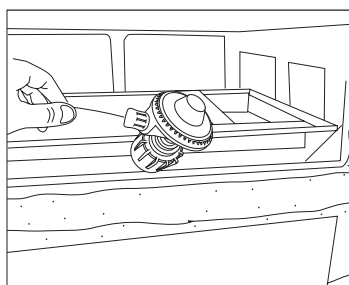
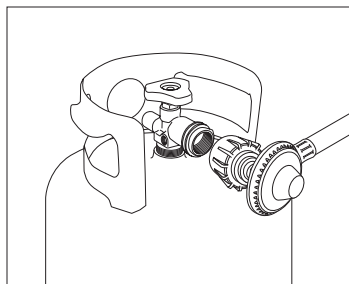
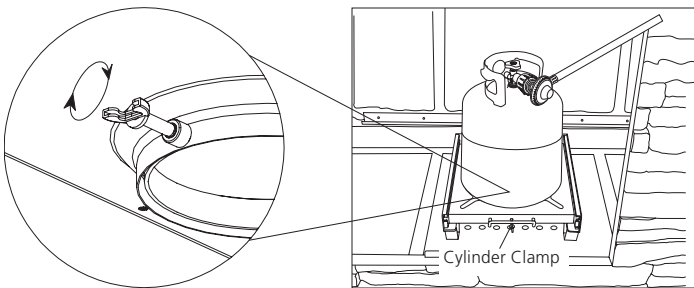
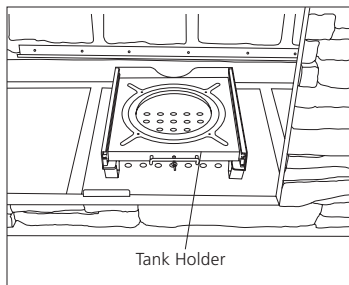
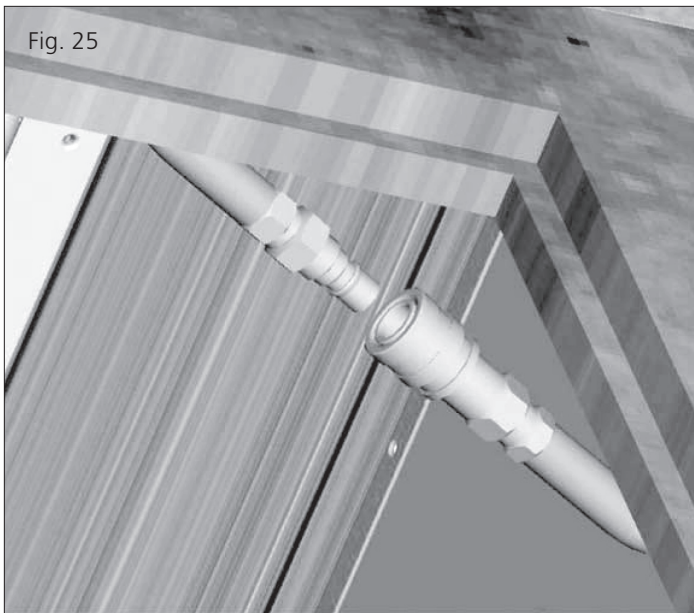
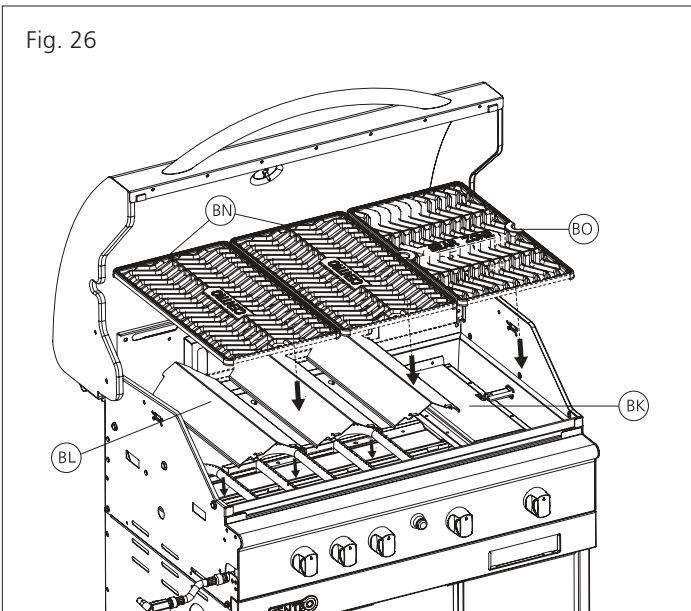

Fig. 26



# 26

Open lid and position the 3 Flame Tamers (BL) above the 3 Main Burners (BI&BJ). Place the 2 cooking grate (BN) into the burner box to the left as shown. Place the "SEARZONE" cooking grate (BO) above the Sear Zone (BK).

**Remember to cover the Sear Zone Burner with cover (BM) when not in use to avoid burner damage caused by damp conditions, rain or snow.**

Fig. 27

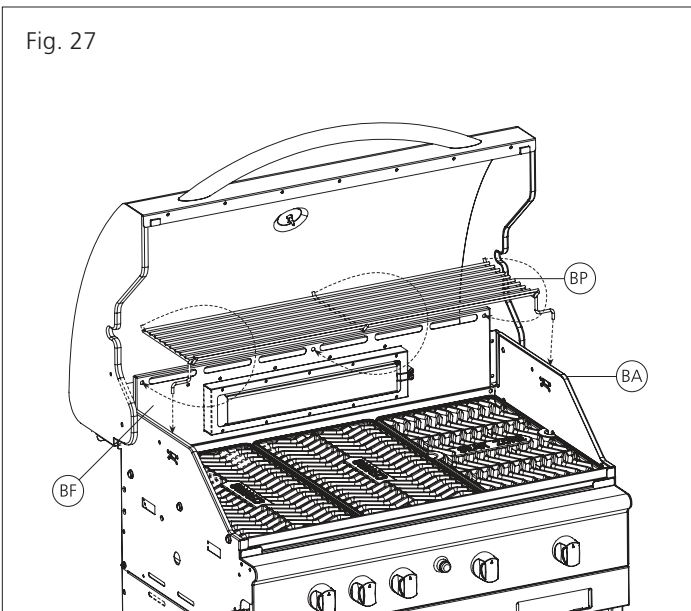

# 27

Attach the Warming Rack (BP) to the Back Burner Brace (BF) as shown. Make sure to insert the front 3 bars into the 3 holes of the Back Burner Brace (BF). Place the two legs of the Warming Rack clip onto the edge of Burner Box Weldment (BA).

Fig. 28

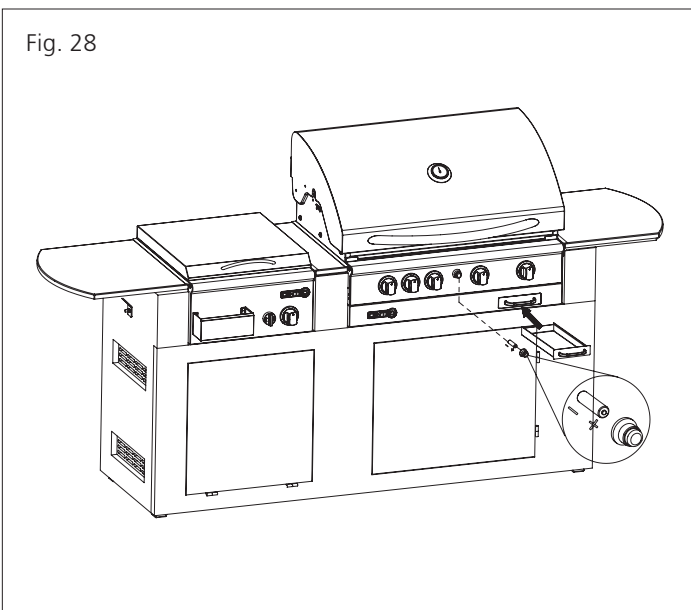

# 28

Unscrew the Igniter Cap and place AA battery which is provided into Igniter (CG) with positive end (+) facing outward. Screw Igniter Cap onto igniter as shown.

Fig. 29

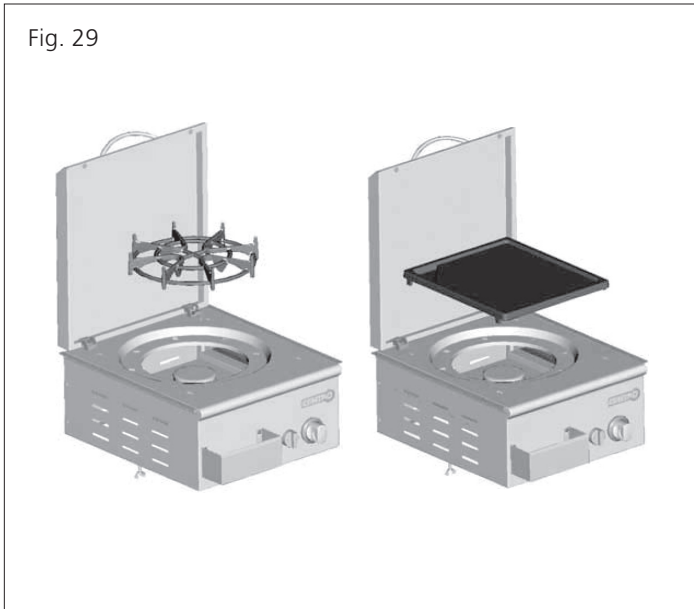

# 29

Place the Side Burner Grate (DD) or Griddle (DC) onto the Side Burner for different cooking purpose.

---

**DISTRIBUTOR**

Trileaf Distribution Trifeuil  
Toronto, Canada  
M4S 2B8

